

ALBERO POMPA - PUMP SHAFT

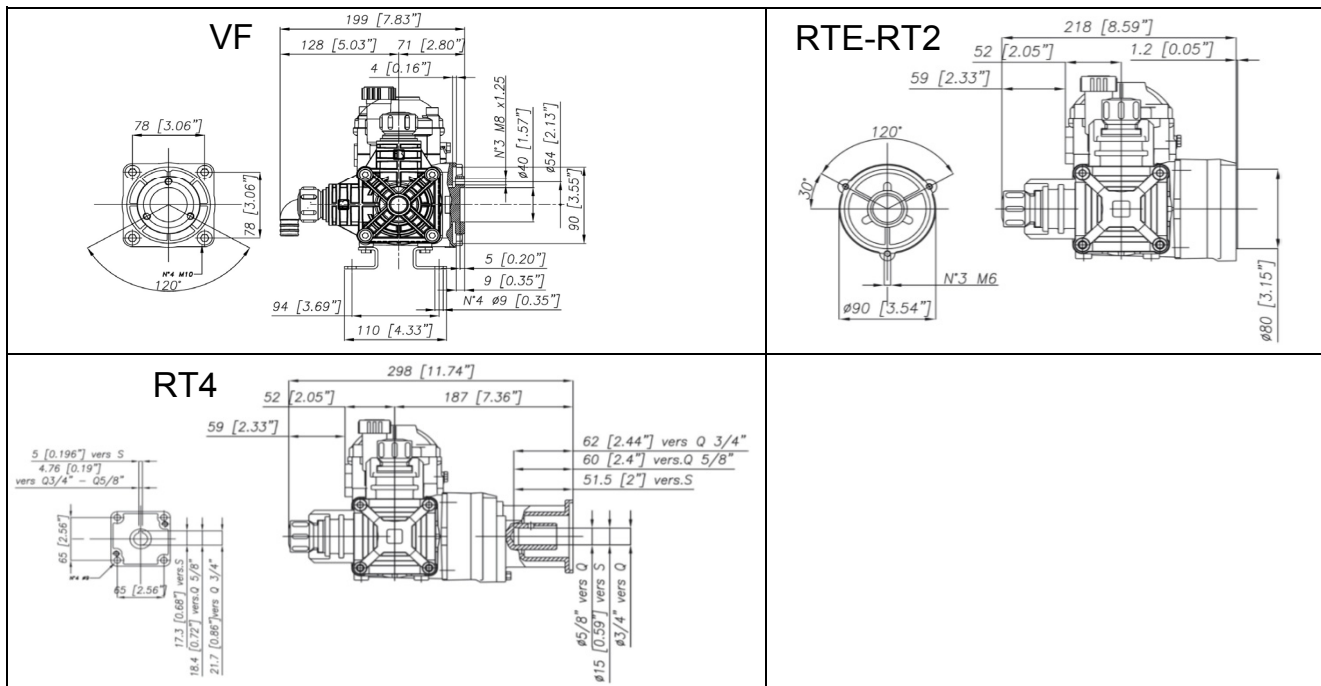

COPPIA DI SERRAGGIO - TORQUE CHART

CODICE - CODE	Q.TY	POS	N-m	Lbr.ft
86.2900.00.2	8	7	10	7,4
03.0021.97.3	2	12	5	3,7
86.1605.00.2	1	17	5	3,7
86.2951.00.2	2	24	10	7,4
86.2059.00.2	2	29	10	7,4
86.3185.00.2	4	35	40	29,5
86.2458.00.2	2	48	10	7,4
86.3500.00.2	4	60	40	29,5
83.8012.00.2	3	65	10	7,4
81.4545.00.2	3	67	10	7,4
86.2566.00.2	4	70	22	16,2
86.2555.00.2				
81.4545.00.2	3	101	10	7,4
83.8060.00.2	3	103	10	7,4

Tolleranza di serraggio: 0/-10%
Tolerance on torque value: 0/-10%

INFORMAZIONI UTILI
USEFUL INFORMATION

LUBRIFICANTE- LUBRICANT:				
POMPA - PUMP:				
OLIO MOTORE O SEMIDRAULICO SAE 30 MOTOR OIL OR SEMI-HYDRAULIC OIL SAE 30				
RIDUTTORE - GEARBOX:				
OLIO MOTORE O SEMIDRAULICO SAE 75-W90 MOTOR OIL OR SEMI-HYDRAULIC OIL SAE 75-W90				
PRESSIONE ACCUMULATORE ACCUMULATOR PRESSURE				
PRESSIONE DI LAVORO - OPERATING PRESSURE	2 ÷ 5	5÷10	10 ÷ 20	20 ÷ 50
ACCUMULATORE ACCUMULATOR	2	2 ÷ 5	5 ÷ 7	6 ÷ 8

KIT MEMBRANE - DIAPHRAGMS KIT

KIT	BUNA - N			VITON			PRE-SET DESMOPAN			PRE-SET DURAMAX		
	1	18	10 15	1	18	10 15	1	18	10 15	1	18	10 15
POSIZIONE ESPLOSO POSITION NUMBER	1	18	10 15	1	18	10 15	1	18	10 15	1	18	10 15
QUANTITA' NEL KIT QUANTITIES INCLUDED	2	1	4	2	1	4	2	1	4	2	1	4

KIT POMPA/KIT VALVOLE - PUMP KIT/VALVES KIT

KIT	KIT POMPA PUMP KIT								KIT VALVOLE VALVE KIT			
	22	61	10 15	40 46	52	6	15	15	2	5		
POSIZIONE ESPLOSO POSITION NUMBER	22	61	10 15	40 46	52	6	15	15	2	5		
QUANTITA' NEL KIT QUANTITIES INCLUDED	1	1	4	1	1	4	1	1	4	4		

POLY 2025

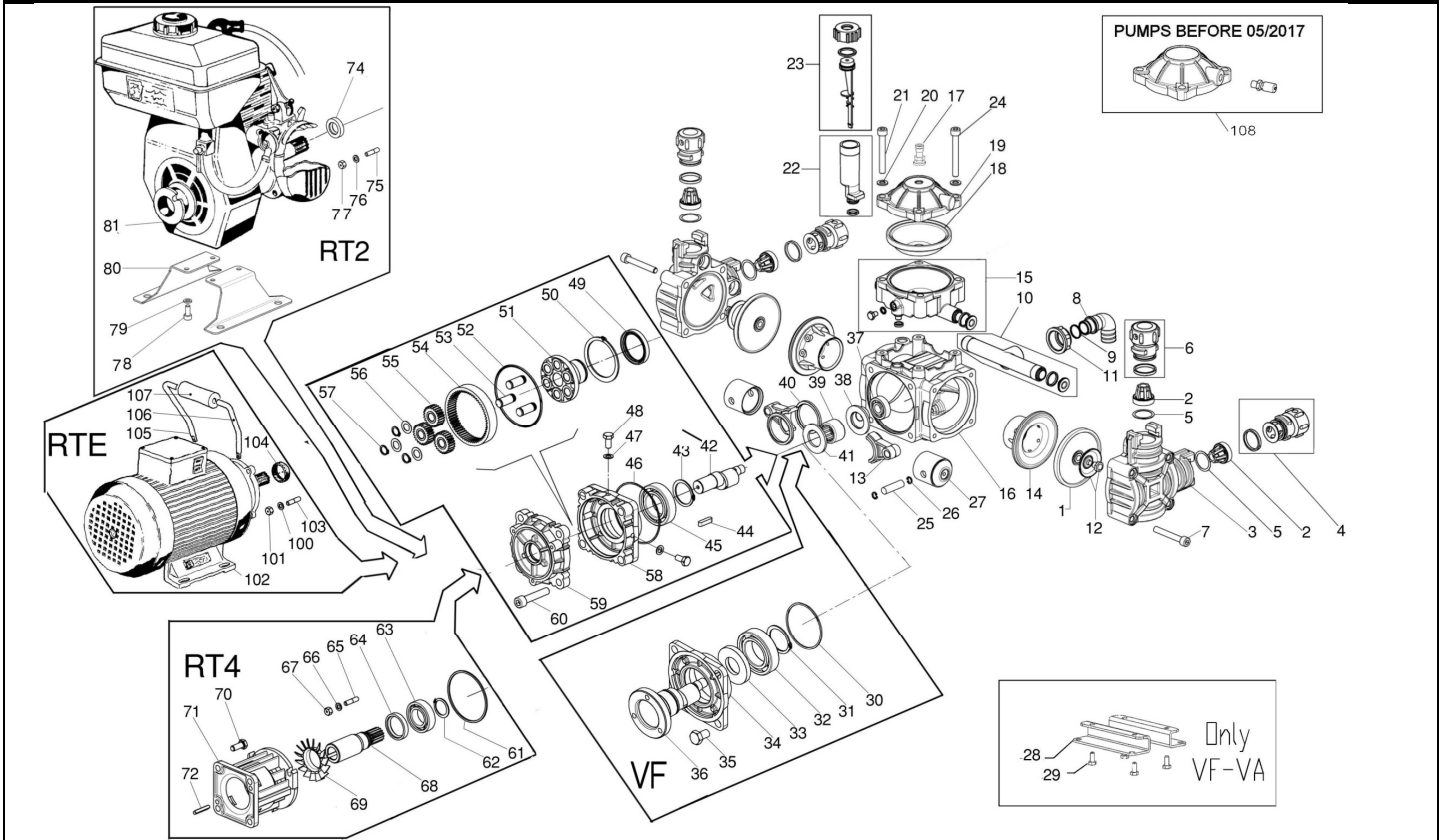

POS.	CODICE PART NO. REF.	DENOMINAZIONE - DESCRIPTION - DESCRIPTION	Q.TY	POS.	CODICE PART NO. REF.	DENOMINAZIONE - DESCRIPTION - DESCRIPTION	Q.TY
1	94.0040.31.2	PISTON DIAPHRAGM	2	46	80.3080.90.2	O-RING 1,78x82,27	1
1	94.0042.00.2DS	PRE-SET DURAMAX PISTON DIAPHRAGM	2	47	84.3642.90.2	WASHER	2
1	94.0042.00.2	PRE-SET DESMOPAN PISTON DIAPHRAGM	2	48	86.2458.00.2	SCREW M8X12 UNI5739	2
1	94.0040.33.2	VITON PISTON DIAPHRAGM	2	49	80.2178.00.2	OIL SEAL D.40X52X7	1
2	94.9828.97.3	VALVE ASSY	4	50	80.1379.00.2	SNAP RING	1
3	94.0302.32.2	PUMP HEAD	2	51	94.0312.09.2	GEARS HOLDER HUB	1
4	94.9869.97.3	KIT INLET CAP	2	52	80.3210.67.2	O-RING 2.62x88.57	1
5	82.4154.50.2	GASKET	4	53	94.0315.49.2	GEAR PIN	3
6	94.9878.97.3	KIT OUTLET CAP	2	54	94.0325.19.2	RING GEAR	1
7	86.2900.00.2	SCREW TCEI M8x55	8	55	94.0323.19.2	GEAR Z=24	3
8	84.0521.00.2	SUCTION CONNECTOR D.20-0,78"	1	55	94.0324.19.2	GEAR Z=26	3
9	80.3060.50.2	O-RING 1.78x12.42	1	56	84.3880.00.2	WASHER D.12x18	3
10	94.9868.97.3	KIT INLET MANIFOLD	1	57	80.1081.00.2	SNAP RING DIA.12	3
11	82.0042.10.2	WING NUT G.3/4	1	58	94.0310.09.2	BEARING HOUSING	1
12	03.0021.97.3	KIT DIAPHRAGM WASHER/SCREW AISI 316	2	59	94.0311.09.2	GEAR BOX	1
13	94.0008.09.2	CONROD	2	60	86.3500.00.2	SCREW TCEI M10X50 UNI5931	4
14	94.0015.01.2	PISTON SLEEVE	2	61	80.3210.64.2	O-RING 2.62x75.87	1
15	94.9867.97.3	KIT DAMPER (X N.P.R.-P.B.P.)	1	62	80.1185.00.2	SNAP RING DIA.25	1
15	94.9924.97.3	KIT DAMPER (X KARIN)	1	63	81.2700.00.2	BEARING 25X47X12	1
16	94.0301.09.2	CRANKCASE	1	64	80.2117.50.2	OIL SEAL D.30X40X7	1
17	86.1606.00.2	AIR VALVE (FROM 05/2017)	1	65	83.8012.00.2	STUD M6X18 UNI5911	3
18	94.0041.31.2	DAMPER DIAPHRAGM	1	66	84.3585.00.2	WASHER DIA.6 UNI6592	3
18	94.0041.33.2	VITON DAMPER DIAPHRAGM (OPT.)	1	67	81.4545.00.2	NUT M6 UNI5587	3
19	94.0003.09.2	DAMPER COVER	1	68	94.0327.42.2	PINION Z=15 20 RT4-3/4"	1
20	84.3685.00.2	WASHER DIA.8,4x15x1,5	4	68	94.0333.42.2	PINION Z=15 20 RT4-D.15	1
21	86.2945.00.2	SCREW TCEI M 8x60 UNI 5931	2	68	94.0334.42.2	PINION Z=15 20 RT4-5/8"	1
22	94.9866.97.3	KIT OIL FILLER	1	69	94.0353.63.2	FAN (OPTIONAL)	1
23	94.9855.97.3	KIT ROP OIL INDICATOR	1	70	86.2566.00.2	SCREW TE 5/16"-24UNF (D.3/4")	4
24	86.2951.00.2	SCREW TCEI M8X65 UNI5931	2	70	86.2555.00.2	SCREW TE M8x20 UNI 5739 (D.15 .5/8")	4
25	85.2006.00.2	PISTON PIN D10X40	2	71	94.0330.09.2	MOTOR FLANGE	1
26	80.0003.00.2	SNAP RING DIA.10	4	72	80.6436.00.2	TAB 4,75X5X30 (D.3/4"D.5/8")	1
27	94.0016.08.2	PISTON	2	72	80.6445.00.2	TAB 5x5x30 (D.15)	1
28	94.0420.61.2	MOUNTING RAIL	2	74	80.2039.00.2	OIL SEAL D15x30x7	1
29	86.2086.00.2	SCREW TCEI M6X14 UNI5931	4	75	83.8012.00.2	STUD M6X18 UNI5911 (RT4)	3
30	80.3080.90.2	O-RING D.1.78X82.27	1	76	84.3585.00.2	WASHER DIA.6 UNI6592	3
31	80.1264.00.2	RING D.35	1	77	81.4545.00.2	NUT M6 UNI5587	3
32	81.2837.00.2	BEARING 35X62X14	1	78	86.2059.00.2	SCREW TE M6X14 UNI 5739	4
33	80.2178.10.2	OIL SEAL 40X52X7	1	79	84.3585.00.2	WASHER D6 UNI 6592	4
34	94.0326.09.2	BEARING HOUSING	1	80	31.1168.75.2	ENGINE SUPPORT CM	2
35	86.3185.00.2	SCREW TE M10X16 UNI5739	4	81	83.4265.00.2	ENGINE 4T CM 70 (Z 9)	1
36	94.0335.26.2	CRANKSHAFT VF	1	100	84.3585.00.2	WASHER DIA.6 UNI6592	3
37	81.2522.00.2	BEARING 12X32X10	1	101	81.4545.00.2	NUT M6 UNI5587	3
38	94.0026.32.2	SPACER	1	102	83.2061.15.2	SPECIAL ELECTRIC MOTOR 220V HP1,5	1
39	81.2688.00.2	BEARING 25X32X20	1	102	83.2066.00.2	ELECTRIC MOTOR 380V HP1,25	1
40	94.0047.76.2	CONROD RING	2	103	83.8060.00.2	STUD M6X25 UNI5911 (RTE)	3
41	94.0027.32.2	SPACER	1	104	80.2092.00.2	OIL SEAL	1
42	94.0321.26.2	CRANKSHAFT	1	105	31.1324.61.2	LEFT HALF HANDLE	1
43	80.1264.00.2	SNAP RING	1	106	31.1325.61.2	RIGHT HALF HANDLE	1
44	80.6473.00.2	TAB 6x6x25	1	107	82.8410.00.2	KNOB	1
45	81.2837.00.2	BEARING 35X62X14	1	108	94.9946.97.3	BALLASTER KIT	1